

6171 Two Tier Browser Box

Assembly Instructions - PAGE 1

Parts Supplied:



www.walib.com.au

A	B	C	D	E	F	G	H	I	J	K
1 x Base Shelf 880mm x 380mm	1 x 2nd Tier Base Shelf 880mm x 380mm	2 x Front Panel 880mm x 85mm	2 x Divider Shelf 880mm x 150mm	4 x Dividers 360mm x 165mm	2 x Side Panel 385mm x 600mm	1 x Back Board 920mm x 600mm	2 x Metal Rods	2 x swivel/ 2 x brake castors	4 x Nut & Bolt Set	38 x Cam Pins

Step 1: screw all cam pins (K) into metal screw holes in parts (C), (F) & (G)



Step 2: Put bolt (J) through top of base shelf (A) and rail (H), secure with bolt. Attach castors (I) to rail.

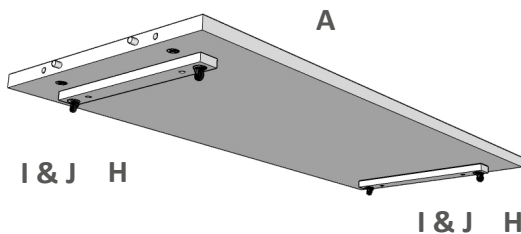

Step 3: Build Tier Display Shelf for Top and Bottom Shelf. Slot Divider Shelf (D) holes facing to back of shelf, onto Dividers (E), then push in Front Panel (C) into Dividers (E). Lock cam pins by turning cam locks 90 degrees. Do two sets.

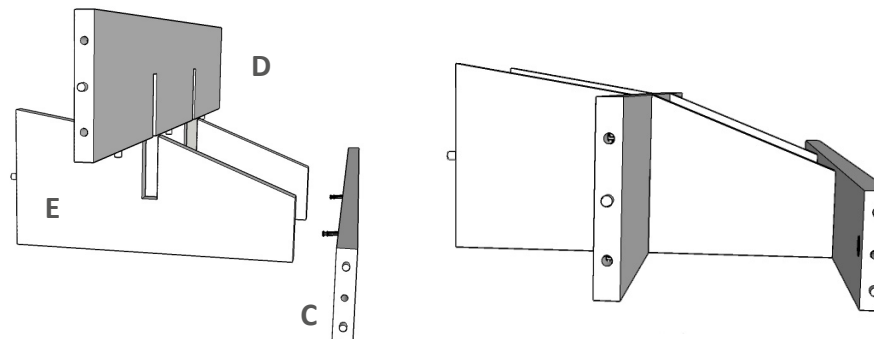

Step 4: Build both shelves by attaching Dividers onto Base Shelf (A) and 2nd Tier Base Shelf (B)

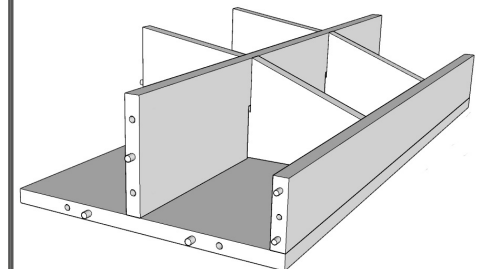

6171 Two Tier Browser Box

Assembly Instructions - PAGE 2

Step 5: Attach side panels (F) to the built shelves. Lay side panel on floor to push in shelves. Lock cam pins by turning cam locks 90 degrees.

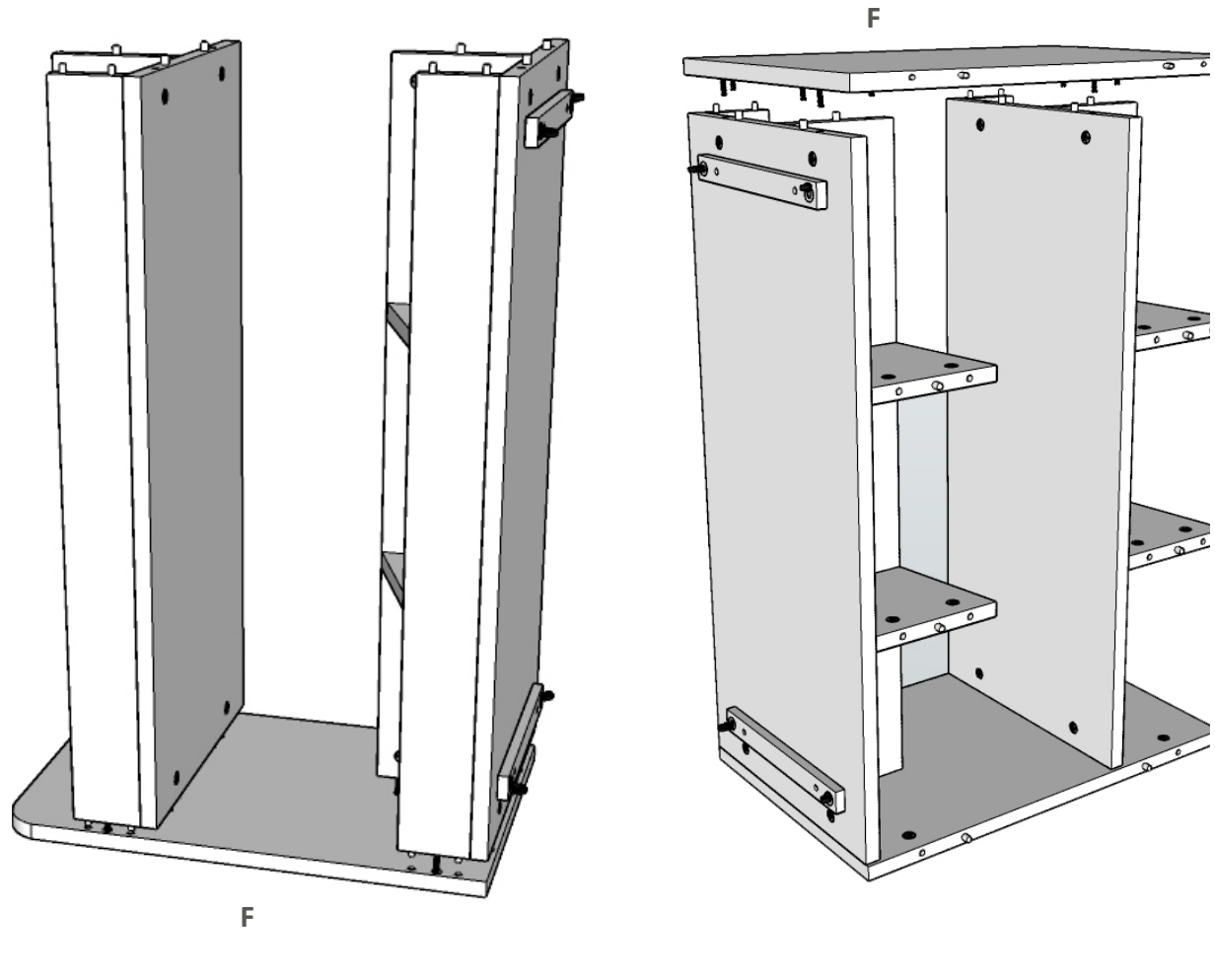

Step 6: Attach Back Board (G) to shelves. Lock cam pins by turning cam locks 90 degrees to push in shelves.

