

7123 Mobile Bus Browser Box

Tools Not Supplied:

Allen Key 4mm
Phillips head screwdriver
Spanner

Read through instructions first prior to starting assembly

Cam pins can be pre-screwed into panels to save time during assembly.



www.walib.com.au

Parts Supplied:

A	B	C	D	E	F	G	H	I	J	K	L
2 x Lower Dividers 595mm x 348mm	1 x Lower Divider Panel 862mm x 346mm	1 x Centre Panel 862mm x 595mm	2 x Upper Dividers 558mm x 180mm	1 x Upper Divider Panel 862mm x 398mm	2 x Face Panels 862mm x 398mm	2 x Side Panel 598mm x 548mm	1 x Base Panel 900mm x 600mm	1 x Steel Frame 770mm x 480mm	2 x swivel castors & 2 x locking castors	30 x Cam Pins 30 x Cam locks (pre-inserted - not loose)	6 x Nut & Bolt Set

Step 1: Slide (B) Long Divider Panel onto (A) Lower Dividers.

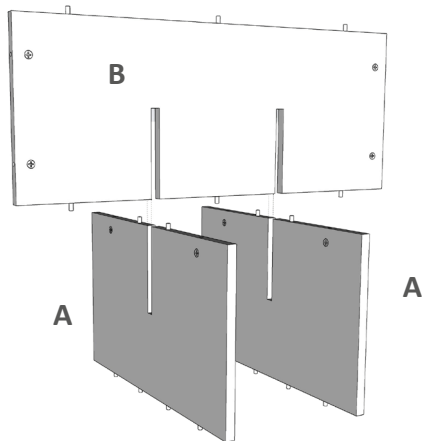

Step 2: Screw 4 cam pins (K) into Centre Panel (C). Push Centre panel onto Dividers. Lock cam locks by turning until tight.

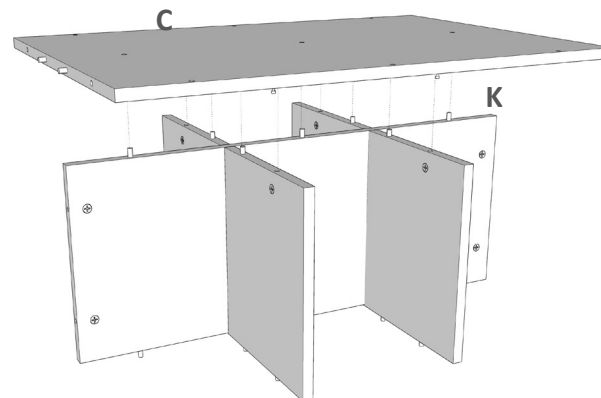

Step 3: Screw 4 cam pins (K) into both Face Panels (F). Push together Upper Dividers (D) into cam pins. Lock cam locks by turning until tight.

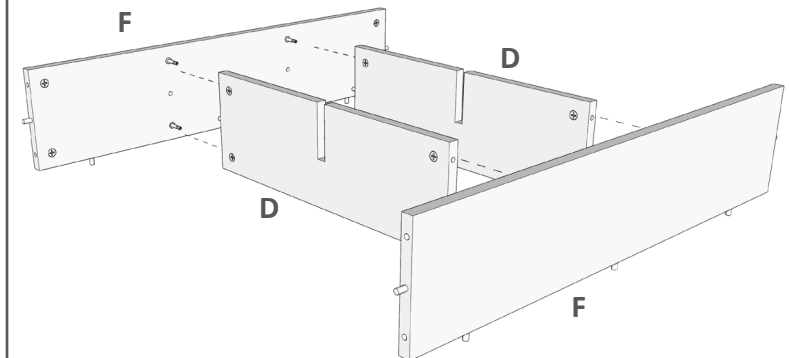

7123 Mobile Bus Browser Box



Step 4: Push upper section onto Centre Flat Panel (C).

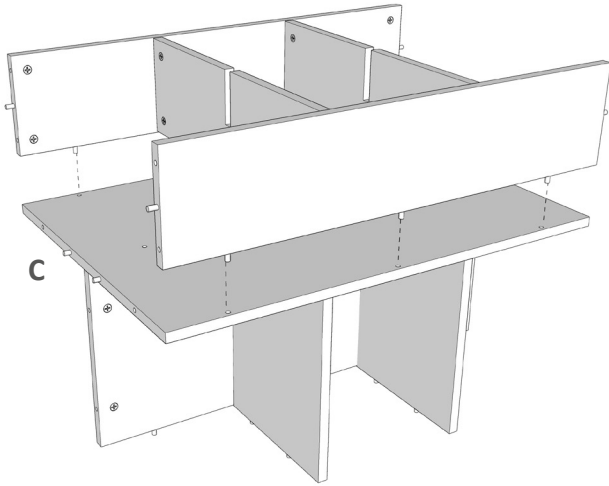

Step 5: Push Upper Divider Panel (E) into upper dividers.

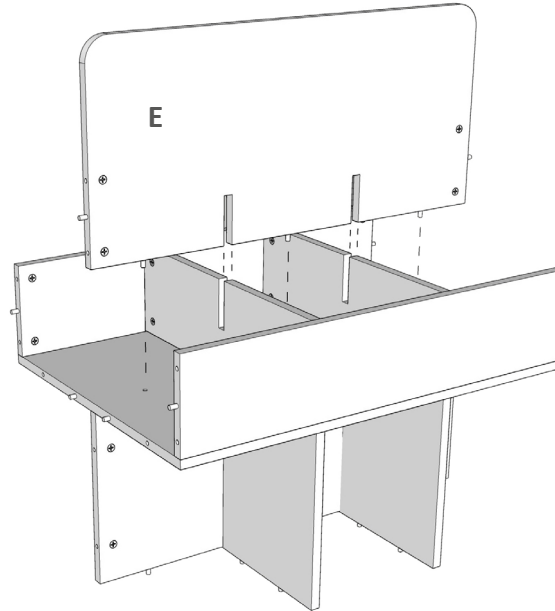

Step 6: Screw 10 cam pins (K) into both Side Panels (F). Push into sides of unit. Lock cam locks by turning until tight.

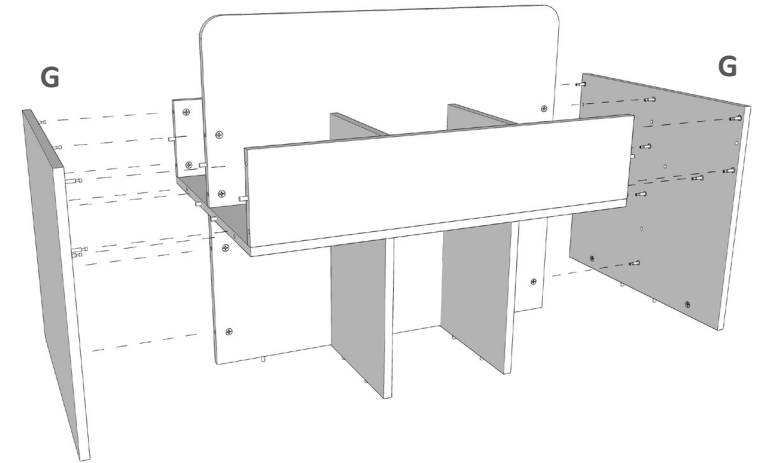

Step 7: Attach steel frame (I) to Base Panel (H). Line up holes on frame and panel and insert Bolt (L) and tighten nuts.

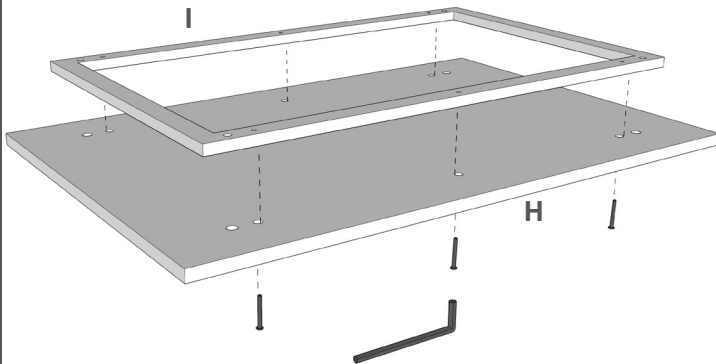

Step 8: Screw in 4 cam pins into other side of Base Panel (H) and then push onto frame. Lock cam locks by turning until tight.

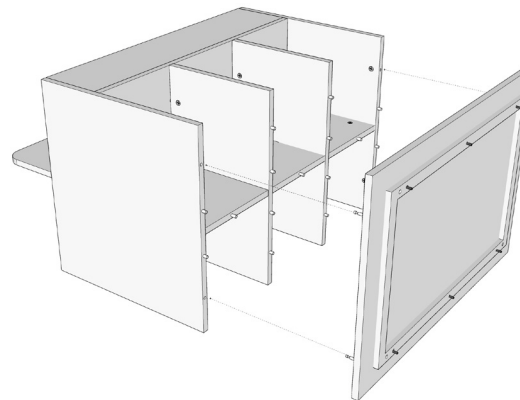

Step 9: Install castors (J) onto base of unit in pre-threaded holes. Tighten until the castors are flush with base.

