

6128 | 7124 Mobile D/S Browser Box

Tools Not Supplied:

Allen Key 4mm
Phillips head screwdriver
Spanner

Read through instructions first prior to starting assembly

Cam pins can be pre-screwed into panels to save time during assembly.



www.walib.com.au

Parts Supplied:

A	B	C	D	E	F	G	H	I	J
1 x Centre Panel 862mm x 596mm	4 x Small Divider Panel 558mm x 182mm	2 x Large Divider Panel 863mm x 400mm	4 x Face Panels 862mm x 182mm	2 x Side Panel 732mm x 600mm	1 x Base Panel 900mm x 600mm	1 x Steel Frame 780mm x 470mm	2 x swivel castors & 2 x locking castors	56 x Cam Pins 56 x Cam locks (pre-inserted - not loose)	6 x Nut & Bolt Set

Step 1: Make 2 internal shelves. For each shelf, screw 8 x cam pins (I) into 2 x Face Panels (D). Push into 2 small divider panels (B). Lock cam-locks by turning until tight.

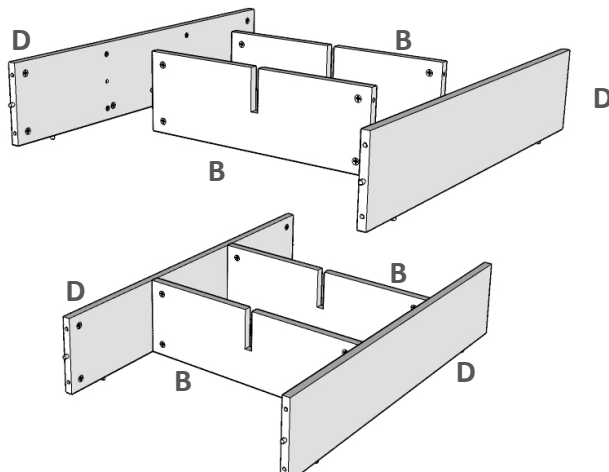

Step 2: Slot 1 x large divider panel (C) into shelf from previous step. Repeat for both shelves.

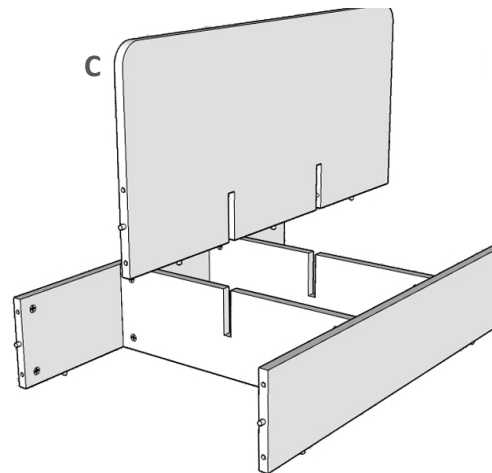

Step 3: Add 4 x cam pins (I) onto centre panel (A). Push panel A onto base of 1 x internal shelf (previous step). Lock cam locks by turning until tight.

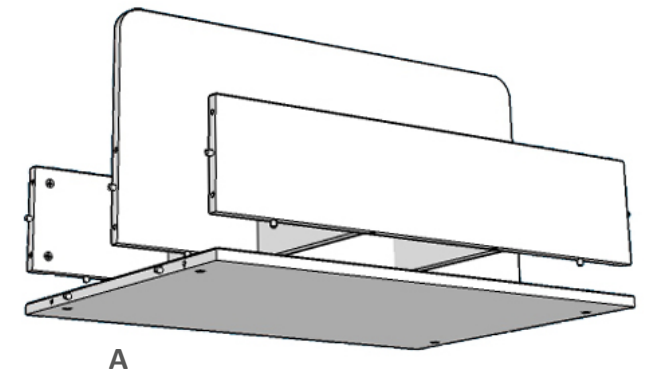

6128 | 7124 Mobile D/S Browser Box

Step 4: Attach end panels and join browser together together.

Screw in 14 cam pins (I) into both Side Panels (E). Push end panels onto both levels of shelves as shown.

Lock cam locks by turning until tight.

NOTE this will be easier if you assemble with the side panels to be the top and bottom for this step.

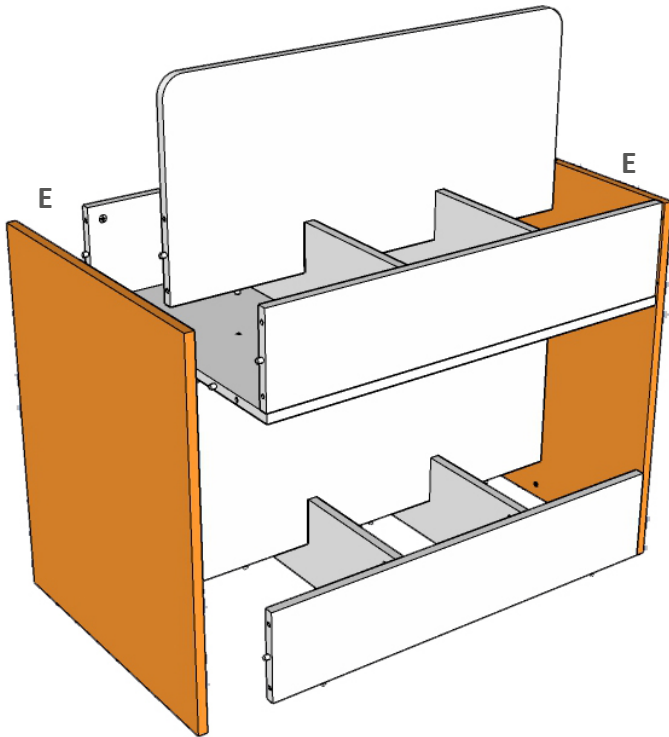

Step 5: Attach steel frame (G) to Base Panel (F). Line up holes on frame and panel and insert Bolt (J) and tighten nuts.

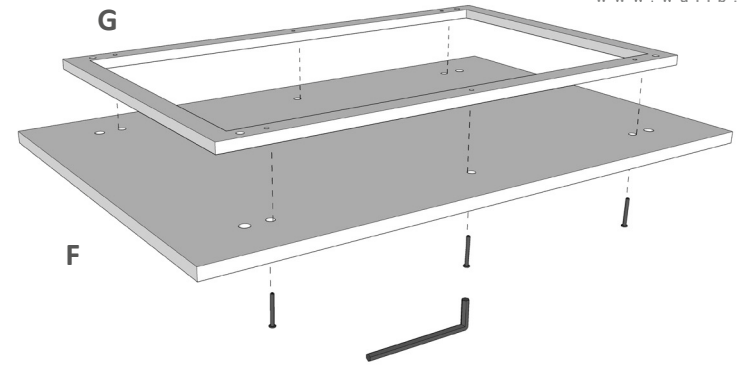

Step 6: Screw in 8 x cam pins (I) into Base Panel (F). Connect base panel (F) to bottom of unit. Lock cam locks by turning until tight.

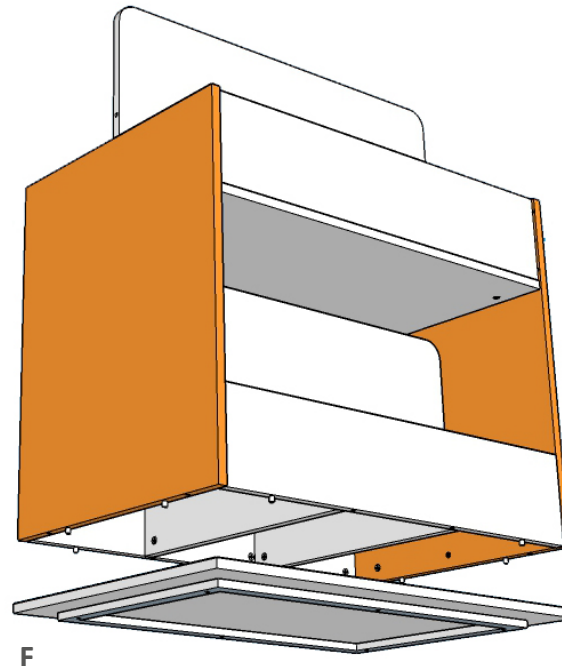

Step 7: Install castors (H) onto base of unit in pre-threaded holes. Tighten until the castors are flush with base.

